



DURBIN

INDUSTRIAL VALVE, INC.

*Sinclair Collins Replacements:

3-WAY 500 PSI VALVE

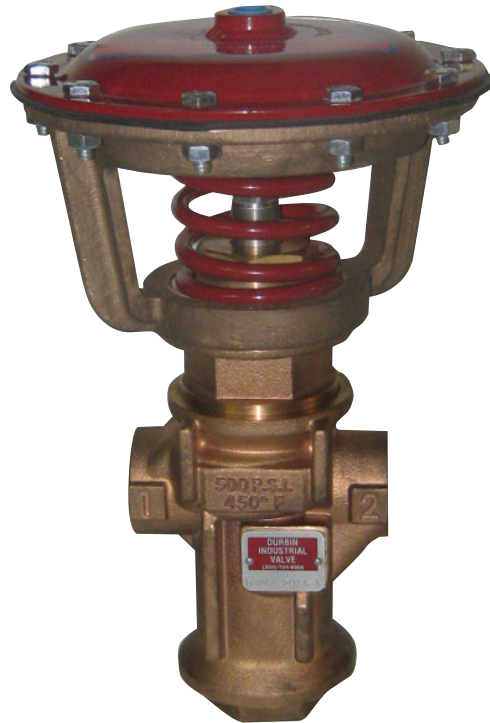

*Durbin Valve is not affiliated with Sinclair Collins

Media Uses:

- Air, cold water, hot water, inert gases, steam, or vacuum service

Features:

- Soft Seated, Class VI positive shut off valve
- Pneumatically operated directional valve
- Port Sizes: 1/2", 3/4", 1", 1 1/4", 1 1/2", 2"
- System pressures: up to a maximum of 500 psi (34 bar)
- Diaphragm Pilot air pressure maximum: 40 psi (2.8 bar)
- Offered in In-line Porting
- Offered in Normally Open, Normally Closed or Mixing Valve
- Available ports in Standard NPT & BSP threads
- System temperature ranges -40°F to 450°F (-40°C to 231°C)
- Wetted components constructed of cast bronze & machined corrosion resistant stainless steel
- Engineered sealing edge meets highest ANSI/FCI 70-2 Class VI leakage rate standards

Benefits:

- Re-buildable valve; rebuild services offered by Durbin Industrial Valve, Inc., or field serviceable with Durbin Industrial Valve, Inc. Rebuild Kits
- Superior materials; more corrosion resistant materials that offer longer valve life
- Engineered for harsher applications; improved seal & seat materials



DURBIN

INDUSTRIAL VALVE, INC.

3-WAY 500 PSI N/C VALVES

| NORMAL VALVE SIDE | | 1/2" | | | | 1" | | | | 1-1/2" | | | | 2" | |
|-------------------|-----------------------|-------------|-------------|-------------|-------------|------------|------------|---------------|---------------|---------------|---------------|---------------|---------------|------------|------------|
| VALVE NUMBER | | D264-20051 | D264-20131 | D264-20061 | D264-20141 | D264-40051 | D264-40131 | D264-40061 | D264-40141 | D264-60051 | D264-60131 | D264-60061 | D264-60141 | D264-60191 | D264-60231 |
| ITEM | DESCRIPTION | 1/2" LG TOP | 1/2" SM TOP | 3/4" LG TOP | 3/4" SM TOP | 1" LG TOP | 1" SM TOP | 1-1/4" LG TOP | 1-1/4" SM TOP | 1-1/4" LG TOP | 1-1/4" SM TOP | 1-1/2" LG TOP | 1-1/2" SM TOP | 2" LG TOP | 2" SM TOP |
| 1 | COVER/LID | C293-023D | C293-018D | C293-023D | C293-018D | C293-030D | C293-091D | C293-030D | C293-091D | C293-036D | C293-030D | C293-036D | C293-030D | C293-036D | C293-030D |
| 2* | DIAPHRAGM | C333-053D | C333-049D | C333-053D | C333-049D | C333-051D | C333-050D | C333-051D | C333-050D | C333-052D | C333-051D | C333-052D | C333-051D | C333-052D | C333-051D |
| 3 | PISTON | C783-048D | C783-032D | C783-048D | C783-032D | C783-081D | C783-061D | C783-081D | C783-061D | C783-102D | C783-071D | C783-102D | C783-071D | C783-102D | C783-071D |
| 4 | SPRING RETAINER | C883-006D | C883-006D | C883-006D | C883-006D | C883-008D | C883-008D | C883-008D | C883-008D | C883-009D | C883-009D | C883-009D | C883-009D | C883-009D | C883-009D |
| 5 | LOCK WASHER (X4) | - | - | - | - | H175-21D | H175-21D | H175-21D | H175-21D | H175-21D | H175-21D | H175-21D | H175-21D | H175-21D | H175-21D |
| 6 | YOKE BOLT (X4) | - | - | - | - | H096-48D | H096-48D | H096-48D | H096-48D | H096-48D | H096-48D | H096-49D | H096-48D | H096-49D | H096-48D |
| 7 | YOKE | - | - | - | - | D283-186D | D283-185D | D283-186D | D283-185D | D283-099D | D283-100D | D283-099D | D283-100D | D283-099D | D283-100D |
| 8 | PACKING NUT | C563-008D | C563-008D | C563-008D | C563-008D | C853-015D | C853-015D | C853-015D | C853-015D | C563-022D | C563-022D | C563-022D | C563-022D | C563-022D | C563-022D |
| 9 | PACKING GLAND/ADAPTER | C013-006D | C013-006D | C013-006D | C013-006D | C013-009D | C013-009D | C013-009D | C013-009D | C013-007D | C013-007D | C013-007D | C013-007D | C013-007D | C013-007D |
| 10* | PACKER KIT | C242-021D | C242-021D | C242-021D | C242-021D | C242-022D | C242-022D | C242-022D | C242-022D | C242-023D | C242-023D | C242-023D | C242-023D | C242-023D | C242-023D |
| 11 | PACKING SPREADER | C713-003D | C713-003D | C713-003D | C713-003D | C713-004D | C713-004D | C713-004D | C713-004D | C713-007D | C713-007D | C713-007D | C713-007D | C713-007D | C713-007D |
| 12 | PACKING SPRING | D293-001D | D293-001D | D293-001D | D293-001D | D293-002D | D293-002D | D293-002D | D293-002D | D293-004D | D293-004D | D293-004D | D293-004D | D293-004D | D293-004D |
| 13* | BODY GASKET(X2) | C383-022D | C383-022D | C383-022D | C383-022D | C383-028D | C383-028D | C383-028D | C383-028D | C383-032D | C383-032D | C383-032D | C383-032D | C383-032D | C383-032D |
| 14 | 3W BODY | C093-151D | C093-151D | C093-152D | C093-152D | C093-149D | C093-149D | C093-148D | C093-148D | C093-153D | C093-153D | C093-150D | C093-150D | C093-266D | C093-266D |
| 15 | SOFT SEAT(X2) | C963-148D | C963-148D | C963-148D | C963-148D | C963-149D | C963-149D | C963-149D | C963-149D | C963-149D | C963-150D | C963-150D | C963-150D | C963-150D | C963-150D |
| 16* | SEAT GASKET(X2) | C383-010D | C383-010D | C383-010D | C383-010D | C383-019D | C383-019D | C383-019D | C383-019D | C383-029D | C383-029D | C383-029D | C383-029D | C383-029D | C383-029D |
| 17 | HEX BOLT | H096-10D | H096-10D | H096-10D | H096-10D | H096-10D | H096-10D | H096-10D | H096-10D | H096-12D | H096-10D | H096-12D | H096-10D | H096-12D | H096-10D |
| 18 | RING/RINGYOKE | D283-140D | D283-139D | D283-140D | D283-139D | C893-022D | C893-048D | C893-022D | C893-048D | C893-031D | C893-022D | C893-031D | C893-022D | C893-031D | C893-022D |
| 19 | HEX NUT | H060-03D | H060-03D | H060-03D | H060-03D | H060-03D | H060-03D | H060-03D | H060-03D | H060-03D | H060-03D | H060-03D | H060-03D | H060-03D | H060-03D |
| 20 | DIAPHRAGM SPRING | D293-157D | D293-157D | D293-157D | D293-157D | D293-147D | D293-147D | D293-147D | D293-147D | D293-051D | D293-054D | D293-051D | D293-054D | D293-051D | D293-054D |
| 21 | WASHER | D223-019D | D223-019D | D223-019D | D223-019D | D223-030D | D223-030D | D223-030D | D223-030D | - | - | - | - | - | - |
| 22 | DUST WASHER | H132-04D | H132-04D | H132-04D | H132-04D | H132-05D | H132-05D | H132-05D | H132-05D | H132-06D | H132-06D | H132-06D | H132-06D | H132-06D | H132-06D |
| 23 | SWIVEL NUT | C643-002D | C643-002D | C643-002D | C643-002D | C643-006D | C643-006D | C643-006D | C643-006D | C643-010D | C643-010D | C643-010D | C643-010D | C643-010D | C643-010D |
| 24 | SWIVEL STEM | D093-037D | D093-037D | D093-037D | D093-037D | D093-086D | D093-086D | D093-086D | D093-086D | D093-146D | D093-146D | D093-146D | D093-146D | D093-146D | D093-146D |
| 25 | SOFT STEM | D093-210D | D093-210D | D093-210D | D093-210D | D093-212D | D093-212D | D093-212D | D093-212D | D093-214D | D093-214D | D093-214D | D093-214D | D093-214D | D093-214D |
| 26* | SOFT SEAT SEAL(X2) | C343-068D | C343-068D | C343-068D | C343-068D | C343-069D | C343-069D | C343-069D | C343-069D | C343-070D | C343-070D | C343-070D | C343-070D | C343-070D | C343-070D |
| 27 | 3W SOFT SEAL WASHER | C353-012D | C353-012D | C353-012D | C353-012D | C353-013D | C353-013D | C353-013D | C353-013D | C353-014D | C353-014D | C353-014D | C353-014D | C353-014D | C353-014D |
| 28 | SOFT SEAL NUT | C553-022D | C553-022D | C553-022D | C553-022D | C553-024D | C553-024D | C553-024D | C553-024D | C553-026D | C553-026D | C553-026D | C553-026D | C553-026D | C553-026D |
| 29 | BOTTOM CAP | C213-177D | C213-177D | C213-178D | C213-178D | C213-175D | C213-175D | C213-176D | C213-176D | C213-180D | C213-180D | C213-181D | C213-181D | C213-201D | C213-201D |
| 30 | STEM ASSEMBLY | C332-104D | C332-104D | C332-104D | C332-104D | C332-085D | C332-085D | C332-085D | C332-085D | C332-088D | C332-088D | C332-088D | C332-088D | C332-088D | C332-088D |
| | SERVICE KIT | C242-057D | C242-058D | C242-057D | C242-058D | C242-059D | C242-060D | C242-059D | C242-060D | C242-061D | C242-062D | C242-061D | C242-062D | C242-061D | C242-062D |



DURBIN

INDUSTRIAL VALVE, INC.

3-WAY 500 PSI DIMENSIONS

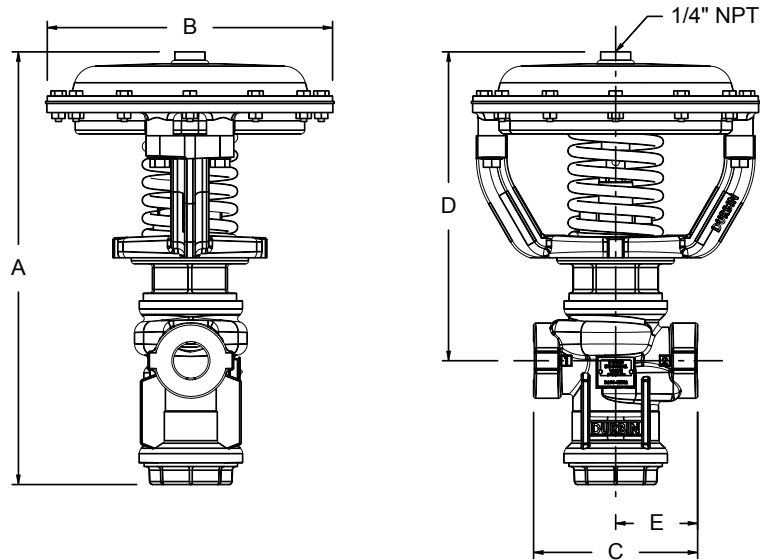

| BASIC VALVE SIZE | PORT TAP | VALVE TYPE | TOP SIZE | A | B | C | D | E | | |
|----------------------------|-----------------|---|---|--------|--------|--------|--------|--------|--------|-------|
| 1/2" | 1/2" & 3/4" | 3-WAY N/C & N/O 2-WAY N/C 2-WAY N/O ANGLE PORTED | LARGE | INCH | 10.53 | 7.25 | 3.88 | 7.03 | 1.94 | |
| | | | | mm | 267.50 | 184.20 | 98.60 | 178.61 | 49.30 | |
| | | | SMALL | INCH | 10.53 | 6.50 | 3.88 | 7.03 | 1.94 | |
| | | | | mm | 267.50 | 165.10 | 98.60 | 178.60 | 49.3 | |
| | | 2-WAY N/O INLINE PORTED | LARGE | INCH | 10.53 | 7.25 | 3.88 | 8.41 | 1.94 | |
| | | | mm | 267.50 | 184.20 | 98.60 | 213.6 | 49.30 | | |
| SMALL | INCH | 10.53 | 6.50 | 3.88 | 8.41 | 1.94 | | | | |
| | mm | 267.50 | 165.10 | 98.60 | 213.61 | 49.30 | | | | |
| 1" | 1" & 1-1/4" | 3-WAY N/C & N/O 2-WAY N/C 2-WAY N/O ANGLE PORTED | LARGE | INCH | 14.01 | 9.50 | 5.38 | 10.01 | 2.69 | |
| | | | | mm | 355.6 | 241.30 | 136.60 | 254.01 | 68.30 | |
| | | | SMALL | INCH | 13.88 | 8.19 | 5.38 | 9.88 | 2.69 | |
| | | | | mm | 352.6 | 208.01 | 136.60 | 251.01 | 68.30 | |
| | | 2-WAY N/O INLINE PORTED | LARGE | INCH | 14.01 | 9.50 | 5.38 | 11.38 | 2.69 | |
| | | | mm | 355.60 | 241.30 | 136.60 | 289.01 | 68.30 | | |
| SMALL | INCH | 13.88 | 8.19 | 5.38 | 11.25 | 2.69 | | | | |
| | mm | 352.60 | 208.01 | 136.60 | 285.81 | 68.30 | | | | |
| 1-1/2" | 1-1/4" & 1-1/2" | 3-WAY N/C & N/O 2-WAY N/C 2-WAY N/O ANGLE PORTED | LARGE | INCH | 17.62 | 11.75 | 6.50 | 12.56 | 3.25 | |
| | | | | mm | 447.60 | 298.40 | 165.10 | 319.01 | 82.60 | |
| | | | SMALL | INCH | 17.66 | 9.50 | 6.50 | 12.59 | 3.25 | |
| | | | | mm | 448.60 | 241.30 | 165.10 | 319.81 | 82.60 | |
| | | 2-WAY N/O INLINE PORTED | LARGE | INCH | 17.62 | 11.75 | 6.50 | 14.31 | 3.25 | |
| | | | mm | 447.60 | 298.40 | 165.10 | 363.50 | 82.60 | | |
| | SMALL | INCH | 17.66 | 9.50 | 6.50 | 14.34 | 3.25 | | | |
| | | mm | 448.60 | 241.30 | 165.10 | 364.20 | 82.60 | | | |
| | 2" | 2" | 3-WAY N/C & N/O 2-WAY N/C 2-WAY N/O ANGLE PORTED | LARGE | INCH | 18.01 | 11.75 | 6.50 | 12.56 | 3.25 |
| | | | | | mm | 457.20 | 298.40 | 165.10 | 319.01 | 82.60 |
| | | | | SMALL | INCH | 18.03 | 9.50 | 6.50 | 12.59 | 3.25 |
| | | | | | mm | 458.01 | 241.30 | 165.10 | 319.80 | 82.60 |
| 2-WAY N/O INLINE PORTED | | | LARGE | INCH | 18.01 | 11.75 | 6.50 | 14.31 | 3.25 | |
| | | | mm | 457.20 | 298.40 | 165.10 | 363.50 | 82.60 | | |
| SMALL | INCH | 18.03 | 9.50 | 6.50 | 14.34 | 3.25 | | | | |
| | mm | 458.0 | 241.30 | 165.10 | 364.20 | 82.60 | | | | |

Cv Rating based on NPT threads • N/O is Normally Open and N/C is Normally Closed

Please contact us for more information at 330.724.9968 or visit us online at www.durbinvalve.com



DURBIN

INDUSTRIAL VALVE, INC.

3-WAY OPTIONAL CONFIGURATIONS

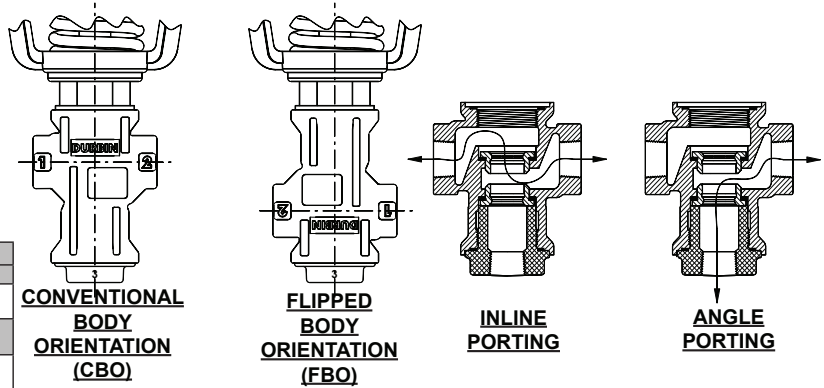

| | VALVE TYPE | PIPING CONNECTION | | |
|-------|--------------------------------|-------------------|----------------------|----------------------|
| | | PORT 1 | PORT 2 | PORT 3 |
| 2-WAY | NORMALLY OPEN ANGLE PORTED | PLUGGED | CYLINDER OR INLET | INLET OR CYLINDER |
| | NORMALLY OPEN INLINE PORTED | CYLINDER | INLET | PLUGGED |
| | NORMALLY CLOSED | INLET | CYLINDER | PLUGGED |

| NOMINAL PIPE SIZE | STYLE | DESCRIPTION | LG TOP | | SM TOP | | CV | | | | BODY ORIENTATION | SPRING | BOT CAP |
|-------------------|----------------------------|-----------------|------------|-----|------------|-----|------------------|------------------|------------------|------------------|------------------|------------|-----------|
| | | | PSI | BAR | PSI | BAR | PORT 1 TO PORT 2 | PORT 2 TO PORT 1 | PORT 2 TO PORT 3 | PORT 3 TO PORT 2 | | | |
| 1/2" | 2-WAY N/C (INLINE PORTING) | MODEL | D264-20012 | | D264-20092 | | 6.21 | 6.31 | - | - | CBO | D293-157D | C213-179D |
| | | PRESSURE RATING | 500 | 34 | 450 | 31 | | | | | | | |
| | | MODEL | D264-20022 | | D264-20102 | | 7.51 | 6.81 | - | - | CBO | D293-157D | C213-179D |
| | | PRESSURE RATING | 500 | 34 | 450 | 31 | | | | | | | |
| | 2-WAY N/O (INLINE PORTING) | MODEL | D274-20012 | | D274-20032 | | 6.11 | 6.51 | - | - | FBO | D293-158D | C213-143D |
| | | PRESSURE RATING | 500 | 34 | 375 | 26 | | | | | | | |
| | | MODEL | D274-20022 | | D274-20042 | | 7.61 | 8.01 | - | - | FBO | D293-158D | C213-143D |
| | | PRESSURE RATING | 500 | 34 | 375 | 26 | | | | | | | |
| | 2-WAY N/O (ANGLE PORTING) | MODEL | D264-20032 | | D264-20112 | | - | - | 7.41 | 8.81 | CBO | D293-158D | C213-177D |
| | | PRESSURE RATING | 500 | 34 | 375 | 26 | | | | | | | |
| | | MODEL | D264-20042 | | D264-20122 | | - | - | 9.61 | 12.01 | CBO | D293-158D | C213-178D |
| | | PRESSURE RATING | 500 | 34 | 375 | 26 | | | | | | | |
| 1" | 2-WAY N/C (INLINE PORTING) | MODEL | D264-40012 | | D264-40092 | | 13.51 | 13.81 | - | - | CBO | D293-147D | C213-174D |
| | | PRESSURE RATING | 500 | 34 | 375 | 26 | | | | | | | |
| | | MODEL | D264-40022 | | D264-40102 | | 17.21 | 16.51 | - | - | CBO | D293-147D | C213-174D |
| | | PRESSURE RATING | 500 | 34 | 375 | 26 | | | | | | | |
| | 2-WAY N/O (INLINE PORTING) | MODEL | D274-40012 | | D274-40032 | | 13.21 | 12.61 | - | - | FBO | D293-147D | C213-139D |
| | | PRESSURE RATING | 500 | 34 | 275 | 19 | | | | | | | |
| | | MODEL | D274-40022 | | D274-40042 | | 17.91 | 17.01 | - | - | FBO | D293-147D | C213-139D |
| | | PRESSURE RATING | 500 | 34 | 275 | 19 | | | | | | | |
| | 2-WAY N/O (ANGLE PORTING) | MODEL | D264-40032 | | D264-40112 | | - | - | 17.91 | 18.41 | CBO | D293-147D | C213-175D |
| | | PRESSURE RATING | 500 | 34 | 275 | 19 | | | | | | | |
| | | MODEL | D264-40042 | | D264-40122 | | - | - | 24.81 | 26.01 | CBO | D293-147D | C213-176D |
| | | PRESSURE RATING | 500 | 34 | 275 | 19 | | | | | | | |
| 1-1/2" | 2-WAY N/C (INLINE PORTING) | MODEL | D264-60012 | | D264-60092 | | 31.91 | 29.71 | - | - | CBO | D293-051D* | C213-182D |
| | | PRESSURE RATING | 500 | 34 | 250 | 17 | | | | | | | |
| | | MODEL | D264-60022 | | D264-60102 | | 35.01 | 32.91 | - | - | CBO | D293-051D* | C213-182D |
| | | PRESSURE RATING | 500 | 34 | 250 | 17 | | | | | | | |
| | 2-WAY N/O (INLINE PORTING) | MODEL | D274-60012 | | D274-60032 | | 31.91 | 29.71 | - | - | FBO | D293-054D | C213-147D |
| | | PRESSURE RATING | 450 | 31 | 200 | 14 | | | | | | | |
| | | MODEL | D274-60022 | | D274-60042 | | 35.01 | 32.91 | - | - | FBO | D293-054D | C213-147D |
| | | PRESSURE RATING | 450 | 31 | 200 | 14 | | | | | | | |
| | 2-WAY N/O (ANGLE PORTING) | MODEL | D264-60032 | | D264-60112 | | - | - | 43.21 | 48.51 | CBO | D293-054D | C213-180D |
| | | PRESSURE RATING | 450 | 31 | 200 | 14 | | | | | | | |
| | | MODEL | D264-60042 | | D264-60122 | | - | - | 45.01 | 49.91 | CBO | D293-054D | C213-181D |
| | | PRESSURE RATING | 450 | 31 | 200 | 14 | | | | | | | |

Cv Rating based on NPT threads • N/O is Normally Open and N/C is Normally Closed

Please contact us for more information at 330.724.9968 or visit us online at www.durbinvalve.com